

A, OUTSIDE DIAMETER

LINE SIZE	150#	300#	400#	600#	900#	1500#	2500#	(5) EDGE WIDTH	L HANDLE LENGTH	W HANDLE WIDTH	LINE SIZE
0.50"	1.875	2.125	2.125	2.125	2.500	2.500	2.750	0.010	4.000	1.000	0.50"
0.75"	2.250	2.625	2.625	2.625	2.750	2.750	3.000	0.015	4.000	1.000	0.75"
1"	2.625	2.875	2.875	2.875	3.125	3.125	3.375	0.015	4.000	1.000	1"
1.5"	3.375	3.750	3.750	3.750	3.875	3.875	4.625	0.015	4.000	1.000	1.5"
2"	4.125	4.375	4.375	4.375	5.625	5.625	5.750	0.030	4.000	1.000	2"
2.5"	4.875	5.125	5.125	5.125	6.500	6.500	6.625	0.030	4.000	1.000	2.5"
3"	5.375	5.875	5.875	5.875	6.625	6.875	7.750	0.030	4.000	1.000	3"
4"	6.875	7.125	7.000	7.625	8.125	8.250	9.250	0.062	4.000	1.000	4"
5"	7.750	8.500	8.375	9.500	9.750	10.000	11.000	0.062	4.000	1.000	5"
6"	8.750	9.875	9.750	10.500	11.375	11.125	12.125	0.062	4.000	1.000	6"
8"	11.000	12.125	12.000	12.625	14.125	13.875	15.250	0.125	6.000	1.500	8"
10"	13.375	14.250	14.125	15.750	17.125	17.125	18.750	0.125	6.000	1.500	10"
12"	16.125	16.625	16.500	18.000	19.625	20.500	21.625	0.125	6.000	1.500	12"
14"	17.750	19.125	19.000	19.375	20.500	22.750	---	0.250	6.000	1.500	14"
16"	20.250	21.250	21.125	22.250	22.625	25.250	---	0.250	6.000	1.500	16"
18"	21.500	23.375	23.250	24.000	25.000	27.625	---	0.250	6.000	1.500	18"
20"	23.750	25.625	25.375	26.750	27.375	29.625	---	0.375	6.000	1.500	20"
22"	26.000	27.750	27.500	28.875	---	---	---	0.375	6.000	1.500	22"
24"	28.125	30.375	30.125	31.000	32.875	35.500	---	0.375	6.000	1.500	24"
30"	34.625	34.875	37.250	38.125	---	---	---	0.375	6.000	1.500	30"

UNLESS OTHERWISE SPECIFIED DIMENSIONS ARE IN INCHES. TOLERANCES PER ISA RP3.2 FRACTIONS $\pm 1/16"$ DECIMALS $\pm .06$ ANGLES ± 10

TABLE 2

TOLERANCES PER ISA RP3.2
BORE DIA. DIA. TOLERANCE
INCHES + OR - INCHES

LESS THAN 0.2500	0.0003
0.2501 - 0.3750	0.0005
0.3751 - 0.5000	0.0006
0.5001 - 0.6250	0.0008
0.6251 - 0.7500	0.0009
0.7501 - 0.8750	0.0010
0.8751 - 1.0000	0.0012
1.0001 - 1.2500	0.0014
1.2501 - 1.5000	0.0017
1.5001 - 5.0000	0.0025
OVER 5.0000	0.0005 PER INCH OF DIA.

TABLE 1

BORE DIA. HOLE DIA.
INCHES INCHES

1.000-3.500	3/32
3.500-5.000	1/8
5.000-6.750	3/16
6.751-8.375	1/4
8.376-10.000	5/16
10.001-11.625	3/8
11.626-13.250	7/16
OVER 1	1/2

GENERAL NOTES:

- ORIFICE PLATES CONSTRUCTED IN ACCORDANCE WITH ASME REPORT NO. 3 / AN 14.3 / ISA RP3.2
- ORIFICE PLATE SHALL BE POLISH FINISHED TO 32 TO 14 MICRO INCHES RMS (SYMBOL 32 TO 14) 1
- THE ORIFICE PLATE SHALL BE FLAT TO WITHIN 0.010" PER INCH OF DAM HEIGHT (D-D/2)
- THE UPSTREAM EDGE OF THE ORIFICE BORE SHALL BE FREE OF NICKS AND SHALL BE SQUARE AND SHARP SO IT WILL NOT APPRECIABLY REFLECT A BEAM OF LIGHT WHEN VIEWED WITHOUT MAGNIFICATION.
- RESTRICTION ORIFICE PLATES (RO & FO TAG #S) DO NOT REQUIRE A DOWNSTREAM BEVEL.

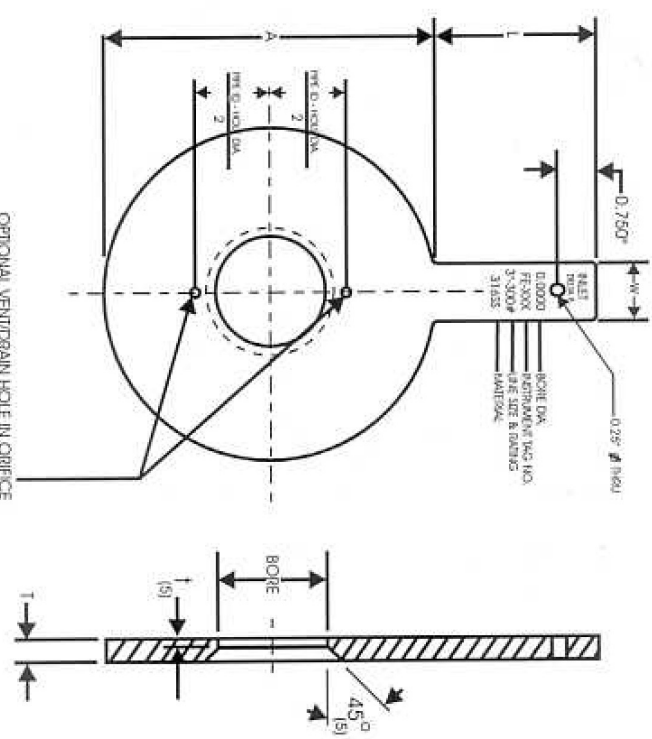

OPTIONAL VENTURIMETER HOLE IN ORIFICE PLATES INSTALLED IN HORIZONTAL LINES. BOTTOM OF LINE FOR GASES AND STEAM OR TOP OF LINE FOR LIQUIDS WITH TRACES OF VAPOUR. SEE TABLE 1 FOR HOLE DIAMETER. PROVIDE ONLY IF REQUESTED IN PLATE REQUEST.

CONCENTRIC ORIFICE PLATE SPECIFICATION & DIMENSIONAL DATA

EBG / Flow Products Div.
13805 Panorama Drive
Austin, Texas 78732